

# AVANT<sup>®</sup> MAGAZINE

AVANT TECNO CUSTOMER MAGAZINE 1/2015

**Avant 760i**  
Powerful and  
environmentally  
friendly p.4

Avant now provides a 2-year warranty! p. 24

Renewed Avant 500 p. 10

# AvantShop

# Avant scale model 1:25 now available!

## Avant scale model

- With bucket and pallet forks
- Telescopic boom
- Scale 1:25
- High quality zink diecast
- Made in Germany



Ask more from your dealer!

# Editorial

## Summer is calling

As the summer is coming we at Avant cannot wait to get outside and start to enjoy the summer with some good machines. During the spring and summer there are always a lot of exhibitions, demo days, open houses, testings etc. So we at sales can definitely spend a lot of time with machines outside. And that is a good thing. We get to meet people, customers and see colleagues in different countries. We also get to show all our new products and listen to customers for new ideas and ways to do things.

Our product development is working hard and in this magazine you can see some great products we have created. The 760i and renewed 500 series are good examples of Avant's good knowledge on its products and that we work on the matters our customers want on their machines. Avant 760i is faster, more silent, more environmentally friendly and more fuel efficient. The renewed Avant 500 series offers more power, speed, durability and is easier to use. All features which our customers have been asking for.

At the moment we have good pace and our sales is going strong despite some turbulent times in Russia and Europe. We believe that through product development and with strong partners we are able to go through these tough times and remain competitive.

A strong indication of our belief in the future is that we have just bought our neighbouring factory, which has altogether 44.000 m<sup>2</sup> of indoor production space. The decision to buy the facility will make it possible to increase our production in the same factory area far into the future. So now we have a good positive pressure to sell more machines and get our sales people moving.

I wish you all a good summer and see you at the shows.

*Jani Käkelä  
Executive Vice President  
Sales & Marketing  
Avant Tecno Oy*

### Avant Tecno Customer Magazine 1/2015



**Editor-in-chief:** Ella Lahtinen / Avant Tecno Oy  
**Publisher:** Avant Tecno Oy  
**Layout:** Viestintätoimisto Tulus Oy  
**Print:** Offset Ulonen Oy, Tampere  
**Edition:** 1500

## Content



- 3 Editorial**
- 4 Powerful and environmentally friendly Avant 760i**
- 10 Renewed Avant 500 series**
- 14 Avant Robot 185 drilling under a historical library**
- 16 New attachments**
- 19 Avant Tecno UK Ltd celebrated its 15th anniversary**
- 20 Avant helps out in Albertslund Denmark**
- 21 Avant proves perfect for block paving specialist**
- 22 Avant 760i – the answer to city maintenance needs**
- 24 Avant now provides a 2-year warranty!**
- 26 Avant Tecno is expanding its manufacturing premises in Finland**
- 27 Did you know this?**





# Powerful and environmentally friendly Avant 760i

Avant takes a big leap forward with the introduction of the Avant 760i. It is a completely new model and the biggest loader from Avant. When driving the new Avant 760i it is easy to see that the R&D efforts have not been in vain. This new loader model with modern engine technology has more power and torque, but at the same time lower fuel consumption, exhaust emissions and noise. Get to know the new Avant 760i – you'll be delighted with the features it offers.



The new Avant 760i is the most powerful model from Avant. One could playfully call it the biggest mini loader in the world. Avant 760i combines successfully the lift capacity and work efficiency of a bigger loader with the versatility and agility of a smaller machine.

Avant 760i is equipped with the Kohler KDI 56 hp/225 Nm diesel engine which complies with the most stringent Tier 4 Final emission regulations. Compliance with the new regulations has been a major challenge for all engine manufacturers, but Kohler in particular has invested vast sums of money in the development of diesel engines in this output category. According to Kohler the development of this engine series has been a project worth more than 30 million Euros.

20% more engine output,  
40% more torque and  
20% lower fuel consumption  
than on Avant 750

Powerful, low emissions  
Kohler KDI engine  
which complies with  
the most stringent  
emission regulations

Easy to use:  
no diesel particulate  
filter (DPF),  
no diesel exhaust  
fluid (DEF)

Large tires mean  
better stability



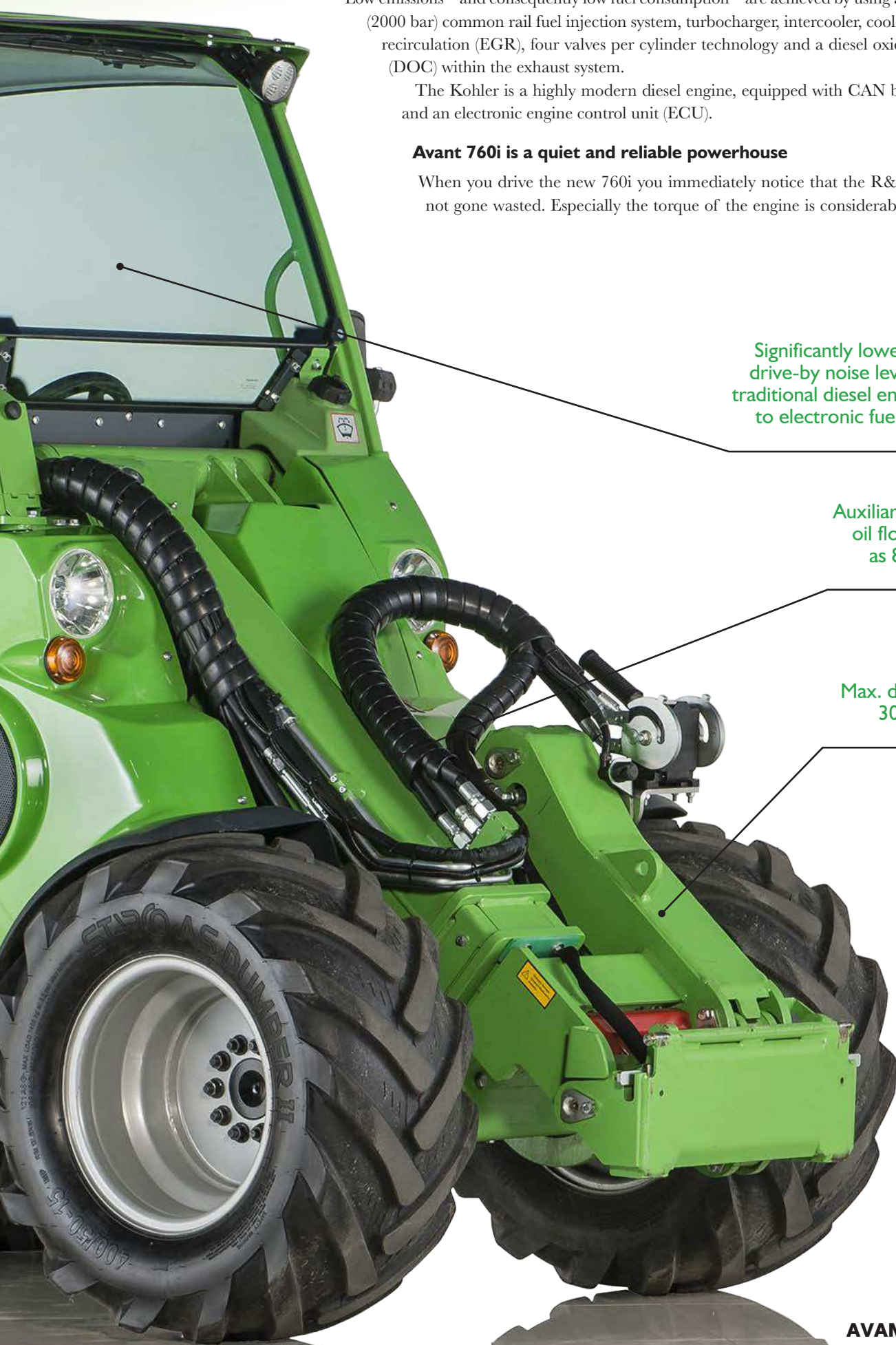

The starting point of the engine design has been Tier 4 final compliance without the need for a diesel particulate filter (DPF) or diesel exhaust fluid (DEF), commonly referred to as AdBlue. Low emissions – and consequently low fuel consumption – are achieved by using a high pressure (2000 bar) common rail fuel injection system, turbocharger, intercooler, cooled exhaust gas recirculation (EGR), four valves per cylinder technology and a diesel oxidation catalyst (DOC) within the exhaust system.

The Kohler is a highly modern diesel engine, equipped with CAN bus technology and an electronic engine control unit (ECU).

### **Avant 760i is a quiet and reliable powerhouse**

When you drive the new 760i you immediately notice that the R&D efforts have not gone wasted. Especially the torque of the engine is considerably higher than ►

Significantly lower cab and drive-by noise level than on traditional diesel engines thanks to electronic fuel injection

Auxiliary hydraulics oil flow as high as 80 l/min

Max. drive speed 30 km/h

on traditional technology diesel engines in this output class. With Avant 760i you can easily work on practically idle engine revs, because the torque curve is very even and max. engine torque is available from almost idling. This gives a completely new feeling of power, as the engine will not stall even if it is heavily loaded on low revs.

Another thing that the driver will notice immediately is the quietness of the machine. Both the noise at the driver's seat and the drive-by noise have been significantly reduced thanks to the modern engine which can be operated at lower maximum revs (2200 rpm). In addition to the lower rpm, the noise of the engine itself is considerably lower than on traditional diesel engines thanks to the electronic fuel injection. The Kohler engine also generates less heat, which allows the use of a smaller cooling fan. This further reduces the noise level.

**Low fuel consumption protects the environment and saves money**

The Avant owner is delighted not only with the increased power and work efficiency, but also with the lower fuel consumption of the 760i. Compliance with the stringent emission regulations means excellent fuel economy as well.

Even though engine output has increased by almost 20 per cent and torque by over 40 per cent, fuel consumption has decreased by over 20 per cent.

Environmental values are becoming more and more important, and the new Avant 760i complies in every respect with the current European emissions legislation. The new Kohler KDI engine also fulfils the requirements of the Tier 4 Final standard which came into effect in North America in the beginning of 2013. Tier 4 is significantly stricter than the Stage 3B emission regulation which is applied in Europe at the moment.

The exceptional thing about Kohler is the way they have achieved the Tier 4 Final compliance. There is no diesel particulate filter (DPF) in the Kohler KDI engine, and it does not require diesel exhaust fluid (DEF). This means that there are no extra maintenance operations or adding of fluids necessary. Just fill the tank with diesel fuel, and the engine takes care of the emissions.

Avant 760i is a new model not only regarding the engine. It has many improved features compared with the Avant 750. Maximum drive speed of the Avant 760i is 30 km/h and

auxiliary hydraulics max. oil flow is 80 l/min – a significant development.

The tire size is also larger, both in diameter and in width.

Larger tires improve handling especially at higher drive speeds and decrease ground pressure when driving on grounds with lower carrying capacity and on sensitive surfaces.





The new Avant 760i complies in every respect with the current European emissions legislation



## Technical information

Length	3190 mm	Auxiliary hydraulics	80 l/min
Width (with standard tires)	1400 mm	Turning radius (inside/outside)	1250/2675 mm
Height	2110 mm	Height lifting	3100 mm
Weight, starting from	2100 kg	Tipping load *)	1600 kg
Standard tires	400/50-15" tractor profile	Max. breakout force at 50 cm	1700 kg
Transmission	Hydrostatic	Engine make and type	Kohler KD11903 TCR
Pulling force	1700-1900 daN	Engine output	56 hp
Drive speed	30 km/h	Fuel	diesel

\*) With a pallet, at 90 cm distance from quick attach plate



# Renewed Avant 500 series

The improved  
driving response,  
power and  
durability

Avant 500 series loaders  
are designed to be  
powerful, simple and  
durable workhorses.  
We concentrated to  
update the machine  
with care.





**A**vant 500 series 2015 model has been completely renewed from its drive transmission. This is implemented with new drive motor which is made by French manufacturer Poclair. What has changed is the brand of the motor and the motor type, from gerotor motor to a radial piston type of motor. Radial piston motors have less internal leakage, which translates to a more precise and powerful drive. Also durability is much better in heavy use. The driver of the loader will notice the improved efficiency of the motor as increased pulling force and a slightly higher operating speed.

***“We have used the Poclair piston motors in larger 600 and 700 series loaders for quite some time. We have received nothing but positive feedback from our customers from the engines durability, power and driving response. Also, the hydraulic parking brake sounds like a small thing but in practice it is actually quite a huge improvement and much more comfortable to use.***

***Because the 500-series machine works in practice, at the professional environment, we wanted to offer this improved drive transmission also to 500 -series.”***

*Jani Käkelä, Avant Tecno Oy*

Although the increases in torque or in speed are not dramatic, these small improvements have a big role in the practical work. In addition, the improved driving response can not be underestimated. Therefore, the machine is easier to run without jerking and it also makes driving easier for someone who is not so familiar with the machine.

The biggest difference between the old and the new drive transmission is best noticed when the machine has been driven more than 1000 or 2000 hours. With the new motor the pulling force of the machine remains the same and actually improves to at least 5,000 driving hours. Also under normal circumstances the motors are maintenance-free. On the contrary a gerotor-type drive transmission loses its pulling force and power in use. The capacity of gerotor type motors is considerably reduced after 1500–3000 hours of operation already.

The hydraulic parking brake has also contributed a significant improvement in the 500 series machines. The same system has been in use for some time in the larger 600 and 700 series. The electrical switch used in the brake system has been found to be a very reliable and handy piece of equipment that helps to enhance the security. The brake is very easy in all situations, and it will also automatically turn on when the machine is turned off.



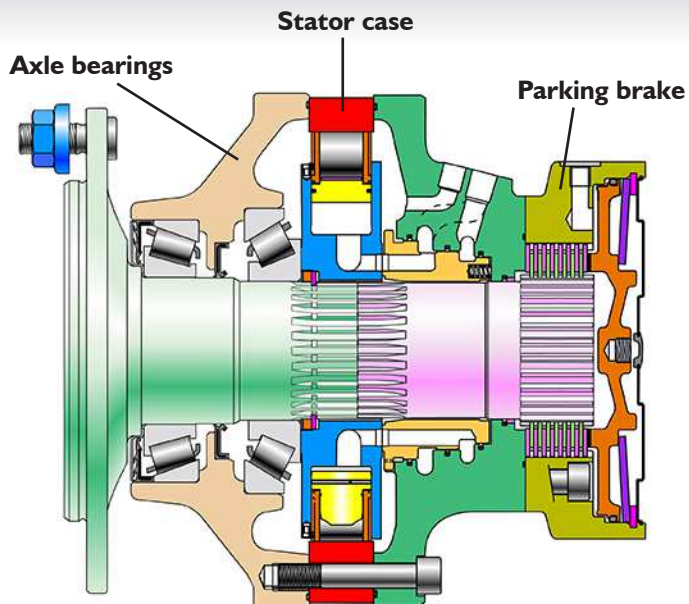

## Drive motor's cross section

The picture shows a cross section of the drive motor in Avant 500 series. Avant 500 and 600 series machines are equipped with a radial piston type motors. The motor achieves the best torque after several working hours and it remains high during long periods of use. The picture also shows the electro-hydraulic parking brake, integrated in the motor. The brake is operated with a switch on the dashboard, and it always locks automatically when the engine is switched off.



### Improvements in a nutshell:

- 10% more pulling force
- 10% more speed
- Hydraulic parking brake
- More robust drive transmission

# Avant Robot 185



## drilling under a historical library

The National Library of Finland located at the center of Helsinki goes through an extensive renovation, which is the largest repair for the building in its 169-year history. The project has recently been voted as the construction site of the year in Finland.



The renovation started last November and will last for a total of two years. In addition to a thorough interior conservation, the first floor is expanded for extra rooms as well as space for heating, ventilation, air conditioning and other building service equipment. The first floor stands on top of granite bedrock, which requires 500 m<sup>3</sup> of rock to be removed.

The prestigious library sets high requirements for the contractors as well as equipment. “When working in a historical building such as this, the job has to be done without dust, water, vibration and exhaust”, says Jyrki Metso from Metson Murskaus Oy. The space is so limited that the first boulders had to be excavated with a sledgehammer and a hand drill. Now the majority of excavation is done with Avant Robot 185 equipped with Doofor rock drill and a hydraulic splitter.

Less than 80 cm wide, the remote controlled Avant Robot can be driven through the narrow corridors of the cellar. The robot drills one meter deep and 45 mm holes, which are then excavated with a hydraulic splitter.



“Because of the limited space, the boulders have to be manually removed. So there is plenty of holes to be drilled”, says Jyrki Metso.

Avant Robot 185 is equipped with a telescopic boom and continuous slewing, which are essential features for productivity. Electrically operated machines enable working in confined spaces without fumes. Otherwise, the job would require plenty of manual work and it would not be cost-effective.

“In such difficult conditions and tight schedule, the machines and service really have to work. We have been pleased with the reliability and features of our robot and drilling. The robot has proven itself with the 500 hours on it, and service and spare parts have been quick if we ever needed anything”, says Metso.

“With these tools and methods we have been able to meet the challenges of the project and to proceed according to schedule”, sums up Jyrki Metso.

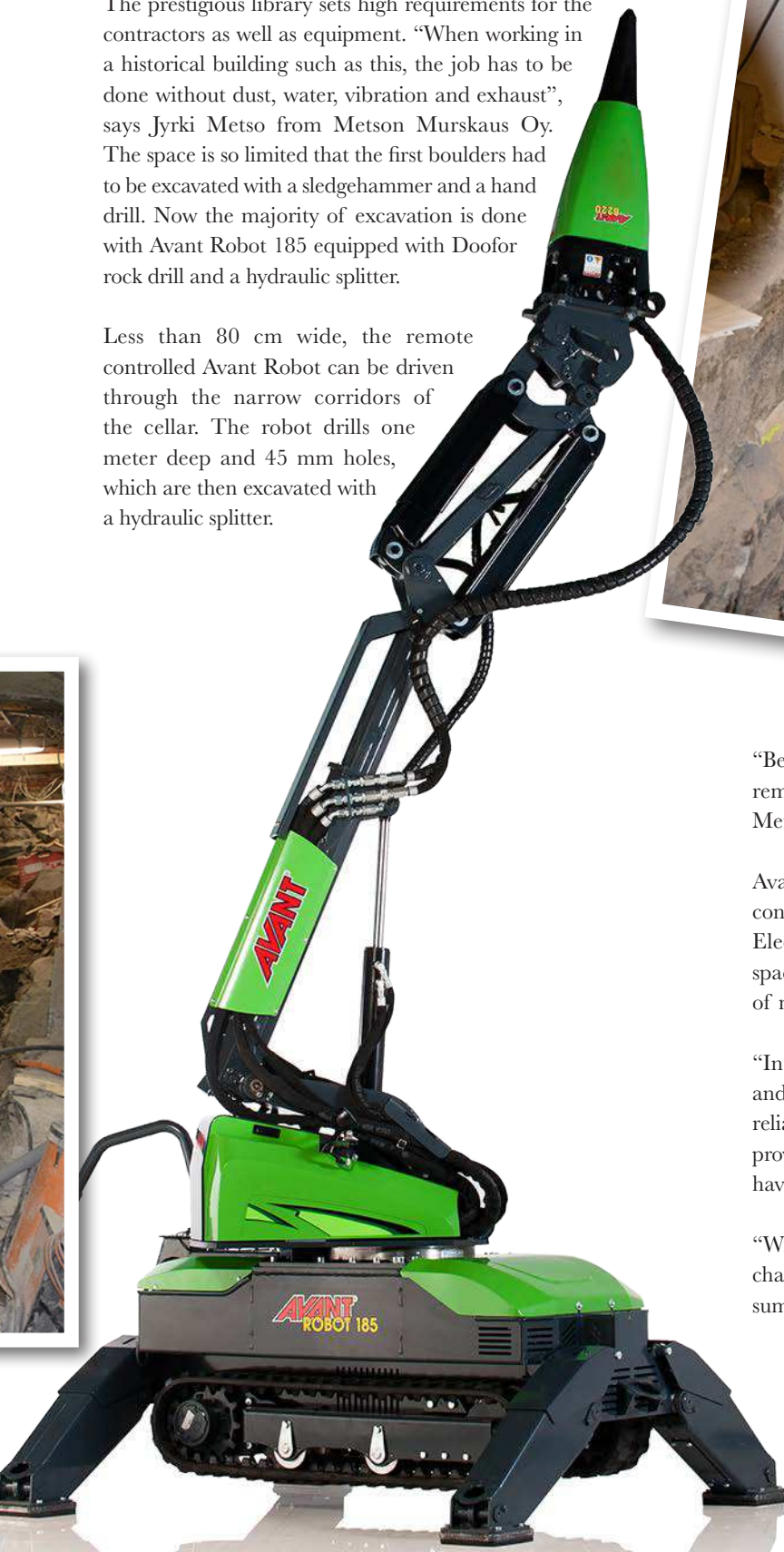

# NEW ATTACHMENTS

## Lawn mower I200

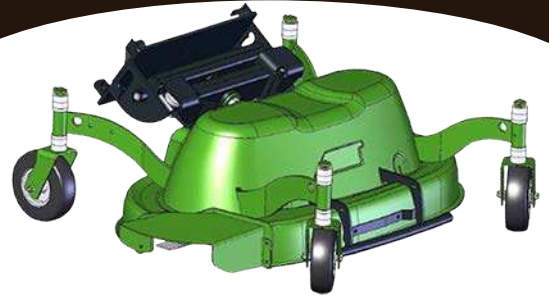

### Lawn mower I200

Working width	1200 mm
Article number	A35965

Lawn mower I200 is a robust and powerful cutter. It is equipped with Avant's optifloat-system, which ensures that the cutter has an optimal ground contact also on uneven lawn. The cutter also has a safety valve that stops the blades if the mower is lifted off the ground. The cutting table of the new model is now pressed into shape, which improves the effectiveness of the mower and reduces the adhesion of the grass to the cutting table.

- The optifloat-system is easy to use and it ensures the best ground contact
- The safety valve stops the blades if the mower is lifted off the ground
- The cutting table which is pressed to shape improves the effectiveness and reduces fouling
- Side discharge as an option

Options: Side discharge A36013

Model	218	220	313S	320S	320S+	419	420	520	525LPG	528	R20	R28	R35	630	635	640	745	750

Very compatible      Compatible      Incompatible

The cutter is bio-mulching, side discharge is an option.

## Bale handler



Bale handler is an economical way to handle wrapped bales, without damaging the plastic wrapping. Distance between the forks can be adjusted manually. The bale handler is a good choice if the bales can always be handled sideways and don't need to be grabbed. This also means that the bale handler isn't quite as versatile as a bale grab.

- A low budget alternative for moving bales
- Easy to use

### Bale handler

Width (min)	1035 mm
Weight	83 kg
Article number	A36262

Model	218	220	313S	320S	320S+	419	420	520	525LPG	528	R20	R28	R35	630	635	640	745	750

Very compatible      Compatible      Incompatible

## XL bucket

The XL snow bucket has a large loading volume. The bucket is designed for the larger Avant 600- and 700-series. This bucket is particularly suitable for light materials such as snow, wood chips, bark-cover etc. for loading and transfer. The inside of the bucket is smooth without reinforcement structures and the forward sides are open. This allows for the best possible emptying of the bucket, even in difficult conditions and with sticky materials.

- Large capacity
- Smooth bucket – no reinforcement structures
- Robust design
- Designed for larger Avant loaders

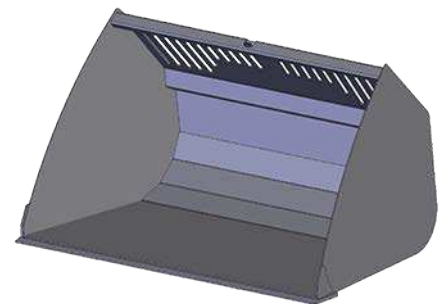

### XL Buckets

Width	Depth	Height	Volume	Weight	Article number
1600 mm	998 mm	880 mm	800 litres	265 kg	A36476
1800 mm	998 mm	880 mm	900 litres	280 kg	A36343

Model	218	220	313S	320S	320S+	419	420	520	525LPG	528	R20	R28	R35	630	635	640	745	750

Very compatible      Compatible      Incompatible



# Horse manure collector

The horse manure collector is a simple and economical way to collect horse manure. It works well on many surfaces (saw dust, horse arenas). It mounts directly on any Avant bucket.

- Economical
- Mounts on any Avant bucket

## Horse manure collector

Width	950 mm
Weight	29 kg
Article number	A36292

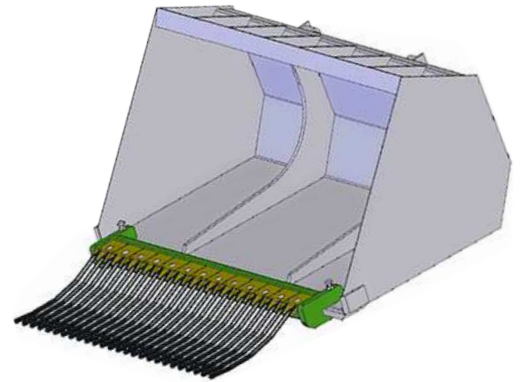

Model	218	220	313S	320S	320S+	419	420	520	525LPG	528	R20	R28	R35	630	635	640	745	750	
	Very compatible	Very compatible	Very compatible	Very compatible	Very compatible	Very compatible	Very compatible	Very compatible	Very compatible	Very compatible	Very compatible	Very compatible	Very compatible	Very compatible	Very compatible	Very compatible	Very compatible	Very compatible	Very compatible

■ Very compatible   
 ■ Compatible   
 ■ Incompatible

# Horse arena harrow

The horse arena harrow is intended for the levelling and loosening of horse arena riding surfaces. The harrow has two spring-loaded tine rows which will loosen the surface, a leveller that will make the surface completely even and a tilling roller that will compress the ground, leaving a great looking finish to the surface. The harrow will not damage the lower levels (understructure) of the riding surface.

## Horse arena harrow

Width	1530 mm
Article number	A21646

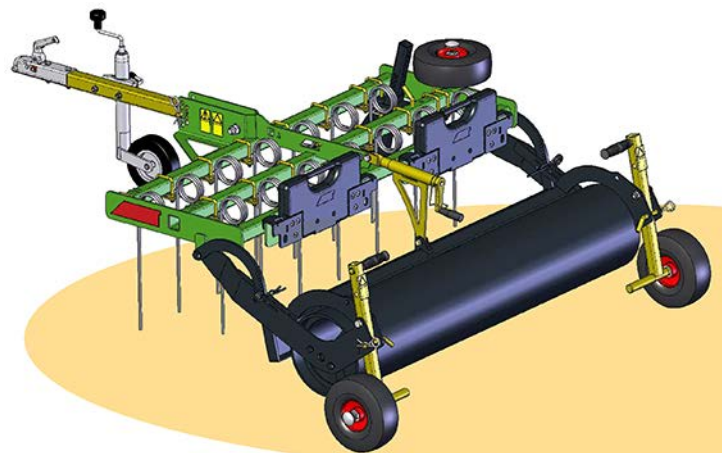

The horse arena harrow features:

- A clearing shovel which will level the sides of the riding arena
- A tilling roller that will smoothen the harrowed ground leaving a great looking finish
- A large wheel that protects the walls of the riding arena in case the harrow hits the wall

Options:

- Extra wheels to the back of the harrow to make transportation easier. Allows moving the harrow yourself. Wheels are mechanically turned up or down. Product number A36593
- Weight with lifting handle. 31 kg weights can be attached to the harrow to increase its weight and to add efficiency to the work. With two additional weights the harrow can be used on almost all surfaces. The same weights can be used as rear weights on the loader. Product number A35957.

Model	218	220	313S	320S	320S+	419	420	520	525LPG	528	R20	R28	R35	630	635	640	745	750	
	Very compatible	Very compatible	Incompatible	Incompatible	Incompatible	Very compatible	Very compatible	Very compatible	Very compatible	Very compatible	Very compatible	Very compatible	Very compatible	Very compatible	Very compatible	Very compatible	Very compatible	Very compatible	Very compatible

■ Very compatible   
 ■ Compatible   
 ■ Incompatible



# NEW ATTACHMENTS

## Concrete mixing bucket

The concrete mixing bucket is a handy tool when you need to make concrete without electricity or when you need to transport or lift the concrete to a place hard to access. The new model is equipped with a 400 mm screw shaft and a guard grill on the bucket. The bucket is emptied from the bottom hatch in the middle of the bucket. Hatch opening is powered by a hydraulic cylinder controlled with an electric directional valve, operation from driver's seat with an electric switch. The bucket is also equipped with a flexible emptying tube which mounts on the bottom hatch. This enables pouring the concrete further away from the bucket.

- Easy and efficient way to mix concrete in places where electricity is not available.
- The mixed concrete is easy and effortless to transport and pour into desired place. Sand can be taken in the bucket directly from the ground.
- Concrete can be ejected up to 2 m height.

### Concrete mixing bucket

Width	1490 mm
Volume	210 litres
Weight	290 kg
Article number	A36494

Model	218	220	313S	320S	320S+	419	420	520	525LPG	528	R20	R28	R35	630	635	640	745	750	
	Very compatible	Very compatible	Very compatible	Very compatible	Very compatible	Very compatible	Very compatible	Very compatible	Very compatible	Very compatible	Very compatible	Very compatible	Very compatible	Very compatible	Very compatible	Very compatible	Very compatible	Very compatible	Compatible

■ Very compatible   
 ■ Compatible   
 ■ Incompatible

## Hydraulic breaker

Avant breakers are specially designed for use with Avant loaders. From three different models you can find one suitable for all 300, 400, 500, 600 and 700 series models. The Avant loader with breaker is a very efficient tool in demolition and refurbishing operations: do the demolition with Avant and breaker, take the debris away with Avant and bucket – very fast and effective.

Another benefit of this combination is its compact dimensions: you can go almost anywhere with this unit. Avant breakers are the fastest, easiest and most efficient breakers for Avant loaders. All hoses, couplings and quick attach brackets are included in the package. In addition to this all set ups have been done to the breaker already at the factory so you can be sure you have a fully functioning package on the worksite.

- Top quality sound isolated Avant breakers are quiet and powerful.
- Breakers are pre-adjusted at the factory to suit Avant loaders. There is a breaker for each Avant model.
- All hoses and adapter plates are included in the packaging so the combination is all ready for work.



### Braker series

Model	Weight	Max bpm	Article number
B105	110 kg	3200 bpm	A32423
B155	150 kg	3000 bpm	A36424
B230	230 kg	2600 bpm	A36425

Model	218	220	313S	320S	320S+	419	420	520	525LPG	528	R20	R28	R35	630	635	640	745	750	
B105	Very compatible	Very compatible	Very compatible	Very compatible	Very compatible	Very compatible	Very compatible	Very compatible	Very compatible	Very compatible	Very compatible	Very compatible	Very compatible	Very compatible	Very compatible	Very compatible	Very compatible	Very compatible	Very compatible
B155	Very compatible	Very compatible	Very compatible	Very compatible	Very compatible	Very compatible	Very compatible	Very compatible	Very compatible	Very compatible	Very compatible	Very compatible	Very compatible	Very compatible	Very compatible	Very compatible	Very compatible	Very compatible	Very compatible
B230	Very compatible	Very compatible	Very compatible	Very compatible	Very compatible	Very compatible	Very compatible	Very compatible	Very compatible	Very compatible	Very compatible	Very compatible	Very compatible	Very compatible	Very compatible	Very compatible	Very compatible	Very compatible	Very compatible

■ Very compatible   
 ■ Compatible   
 ■ Incompatible

# Avant Tecno UK Ltd celebrated its 15th anniversary



Avant Tecno Oy's product export to England started as early as 1992. The company was only 1 year old then but already looking for customers all over Europe, as at that time the domestic market was down due to the depression.

Our export to the UK was initiated by Mr Chris Hanson, who bought some Avant products for his company. He introduced the Avant machines to Eurogreen, which became our first actual importer. Through Mr Hanson, we also made valuable contacts in Australia and New Zealand, and our export to these countries has exceeded €10 million so far.

We conducted business in England with Eurogreen until 1996, when we decided to change the importer because annual sales had remained at the level of around €150,000. Avant sales were thereafter led by a company owned by Mark Butler. The sales quickly doubled but remained at this level. Mark Butler had already earned millions when selling his flourishing lease company, which probably decreased his desire for growth.

We believed that by starting an import company of our own we would establish a firmer foothold in the market. To reach this goal, Avant Tecno UK Ltd was founded in 1999 with Nigel Litherland in the saddle. Nigel had already gained some experience with the Avant products when working for Butler. This change boosted the Avant business and we soon reached turnover of €1 million.

Start-up of an import business in a rather new business area with an unfamiliar brand is a demanding task. The leader must be a multi-skilled person who can manage not only sales, but also the company and the cash flow.

These requirements caused some communication problems between us and the English managing director. Therefore, we decided to proceed with Finnish efforts.

In 2004, Jukka Vaattovaara took the wheel of the company. Jukka had already gained much experience from sales and marketing of Avant products in both Finland and in the export business. With a strong belief that we would have great opportunities to increase sales of Avant significantly in the UK, we set very demanding goals for the company's growth.

Our first business premises in 1999



were located in Norfolk. They were considered temporary facilities which would be changed to more suitable ones along with the leaps in the business. Finally, in 2005, our company moved to new premises in Manor Farm. 2005 was also a year of positive results for us. Since then the business in UK has shown positive figures.

During the economic recession in 2008, we managed to maintain Avant UK's turnover on the same level as in the previous year, whereas the next year turned out to be another period of growth.

Avant UK currently employs seven people in Norfolk. The Avant brand has become rather well-known there, while in our own region we hold the position of market leader. The future will bring a lot of work and opportunities. After the "new start", our volume has more than quadrupled. We believe that the positive growth will continue thanks to the development of the Avant product range, the good economic situation in the UK, and efforts made by our personnel.

On 31 October 2014, we celebrated Avant UK's 15th anniversary. The ceremonies included recognition of the personnel and also an official change of the managing director. After 10 years as leader of the company, Jukka Vaattovaara returned to work for Avant in Finland and handed management of the company to Raimo Ala-Korpi.

We wish Raimo the best of luck and success in his demanding task. We strongly believe that he will enjoy his new role and continue the growth and success of the company.



**Site Equipment Demonstration fair  
Milton Keynes, UK, May 2003.**



**Site Equipment Demonstration (SED),  
Rockingham 2007.**



**SALTEX 2008, Windsor Racecourse, Berks.**



# Avant helps out in Albertslund Denmark

Since 2011, when a new Avant was bought to the housing association Blokland in Albertslund, Denmark, the staff of the association have been a bit more excited about coming to work. Avant makes life easier for employees and helps with various tasks concerning the daily maintenance of the areas at Blokland.



total of 303 housing units, which are divided into four blocks. A normal workday at Blokland consists of property maintenance and maintenance of the large green area surrounding the premises. Currently there are four people responsible for the different maintenance tasks and there is plenty of work for all four men as well as the Avant. Within a few years the workers have become world-class drivers of Avant. "One of the boys is really an excellent Avant-driver. When you see him, you could almost think, that he was born to be behind the steering wheel of Avant – that's how good he is," laughs Freddie and continues, "but part of this is probably due to the fact that we use the Avant so much in our daily work life and it is so easy to use – we just automatically become good drivers.

Since the acquisition of the loader, the attachment range has been expanded actively. At the moment there is a dozer blade, a jib boom, a fingerbar mover

(hedge trimmer), a set of pallet forks and a 4-in-1 bucket. "It may well be that we will purchase even more attachments in the future – Avant provides a wide range of opportunities for the purchase of attachments and expanding the attachment range," says Freddie. In addition Blokland has chosen to equip their Avant 635 with a GPS transmitter, so it is always possible to see where the loader is located. Furthermore the loader is also equipped with a DLX CAB, so in the winter time the staff gets to enjoy the warm and safe cabin, as well as in the summer heat it is pleasantly cool in the work area – not to mention the radio, which is part of the standard DLX cab.

In Blokland Avant is used on a daily basis for example in moving the beds and televisions which are thrown to the loose waste. "Here, the people may, for example, throw an old washing machine into a normal waste container by mistake, so we are very happy to have Avant, to

help us to remove the washing machine from the container and put it into the proper one," says Freddie. In addition to this type of waste management, Avant is used in handling all the heavy work, such as street salting and plowing, boulders and large stones moving as well as extensive green grass maintenance, in the Blokland property area.

Different kind of tasks within property maintenance have to be taken care of all year and that is why it is important to have a machine with plenty of power and agility. These are the reasons why Avant 635 was bought by Blokland three years ago. People in Blokland are very happy with their green helper.

"Well, we are just so grateful and satisfied with our Avant. Nowadays I can't imagine working without the machine – it is a very important part of our everyday worklife," says Freddie S. Olsen and continues "Before we got the loader, we had to take on too much physical hard work and heavy lifting. I believe that especially our backs are quite happy about and thankful for the loaders arrival here."

Blokland is part of the cooperative housing society Vridsløselille and has a





# Avant proves perfect for block paving specialist

A UK based block paving company has recently purchased its ninth Avant compact loader since discovering the Finnish manufactured machines some 12 years ago.

Established in 1987, family owned Tecni:Block specialises in all types of paving for both commercial and domestic customers and now wouldn't be without its fleet of green Avants.

Commenting on its choice of machine, Tecni:Block's managing director Phil Annable said: "I really didn't think our first Avant would last five minutes on our type of work, but I have to say they have since proved to be absolutely brilliant with one of our 635 models now over eight years old and still going strong."

The key feature that attracted Tecni:Block to the Avant units is their ability to lift 1 tonne plus packs of blocks and place them into position prior to

laying. In addition, the pallet forks can be quickly changed to a bucket for sand handling and levelling or a vacuum lifter when working on obstacles such as steps or even a breaker when required.

"Our latest Avant 750", continued Mr. Annable, "has a little more lift capacity which enables it to handle larger blocks with ease and also benefits from 2-speed drive which is useful when we have to carry packs some distance on large sites."

With several gangs working at different locations throughout the Midlands, Tecni:Block also likes the fact the Avants can be safely towed to site behind a typical 4x4 vehicle.



# Avant 760i

## – the answer to cities maintenance needs

When Avant 760i was introduced in 2014, many city maintenance managers showed immediate interest. Palmia's Property Maintenance Services in Helsinki were also excited about the newcomer.

**W**e had an Avant 750 in trial use a year earlier, and it worked wonderfully. Since our employees liked the machine, we were excited to hear that the company was rolling out a machine that would meet our needs even better', says Janne Liespalo, the service supervisor of the southern region at Palmia. He continues: 'We were such early birds with Avant 760i that we are in the position of a messenger, so to speak.'

The idea to acquire the machines originated from the initiative and activity of Konetalo Vainikka, an Avant retailer. In 2013, Vainikka suggested that Palmia try out an Avant machine, and Palmia has carried on down this path. At the moment, Palmia uses one Avant 760i of their own and seven leased machines in the maintenance of the streets and buildings of the southern and eastern regions of Helsinki.

The machines are used in the ploughing, sanding, sweeping and washing of the streets.

'We mostly use the machines between November and April. Our need for the machines is significantly greater during this period than in the other half of the year. The leasing agreement is very advantageous for us, because the machines do not have to stand unused for six months of the year. I believe that the price of the lease agreement will prove more profitable for us in the long run. During the summer and autumn, we can manage with our own equipment. It would be a different case if we also had to maintain the parks of the city', Liespalo says.

Even though the machines have been acquired primarily for winter use, the future will tell what the year-round need will be. Regional divisions and responsibilities are determined for a year at a time, and it



is very likely that Palmia will use Avants in the future, too – however, the exact number of the machines remains uncertain.

### Suitable for both the job and the users

Property maintenance selects machines on the basis of several criteria. According to Liespalo, the most important of these are size, power and speed. It is also essential that the machine has a simple driving logic that is easy to learn. Palmia cooperates extensively with numerous learning institutions and employs many apprenticeship students. It is important that new, young workers can take in the operation and dimensions of the machine right from the first driving sessions.

'The size, agility and power of the Avant are in a class of their own. The

**'Our employees have noticed that the machine is strong for its size and has a lot of power for pushing snow. In addition, the attachments are efficient and functional in use.'**

Janne Liespalo,  
Palmia's Property Maintenance Services

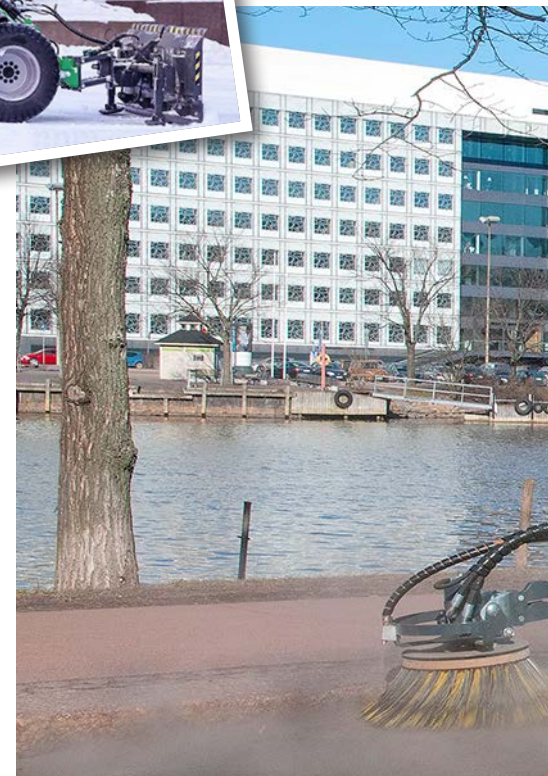

30 km/h speed of the new 760i is also suffice for driving in the city centre', Liespalo sums up. At first, he was a little nervous about the driving logic of the Avant, because contrary to machines of other manufacturers, it is operated by using pedals to change the direction, while the throttle is operated by hand. However, there have been no problems, and the drivers get along with the machine very well.

Other important selection criteria include the price and use environment – the machine has to be suitable for its use.

According to Liespalo, the Avant is excellently suited for 70 percent of the maintenance sites. The remainder of the sites can be maintained with the Avant, too, the only difference being that some tasks would be quicker with a larger machine. On the other hand, many tight spaces can only be handled by the Avant. The slim, agile and low-framed machine is able to get by in very tight places and bend everywhere.

One of the absolute strengths of the Avant is its telescopic boom. The boom considerably expands the reach of the machine. In the small courtyards of the centre of Helsinki, the telescopic boom speeds the work up considerably, as the machine can reach the building in one go.

***'The multi-connector system is exemplary. Earlier, we always had to fight with frozen connectors or hydraulic pressures in the hose. There is none of this with the Avant.'***

*Janne Liespalo,  
Palmia's Property Maintenance Services*

So far, Palmia has acquired a bucket, a snow blade, a sand spreader and a collecting broom. The company has tested the high pressure washer for washing the streets during the spring, and it is now on the acquisition list thanks to its properties. It is easy to sense satisfaction with the attachments of the Avant.

The collecting broom, receives praise

machines and a short familiarization period, objections have disappeared. 'Our employees have noticed that the machine is strong for its size and has a lot of power for pushing snow. In addition, the attachments are efficient and functional in use', Liespalo explains.

The biggest thing that still requires some getting used to is the above-mentioned driving logic. This is a matter of adaptation, and Palmia is confident that in a while, the employees will learn to operate the machines like any other vehicle.

One of the best features of the Avant is the multi-connector system. Palmia has found it practical and exemplary. 'Earlier, we always had to fight with frozen connectors or hydraulic pressures in the hose.



### **An impressive range of attachments**

The extensive and diverse range of attachments further increased Palmia's interest in the Avant. Practically every attachment needed in property maintenance can be added to the machine. At the moment, Palmia gives the attachment selection a score of 9 out of 10. According to Liespalo: 'The range of attachments is wide and there's a lot of power. Adding a snow blade with adjustable width in the selection would bring the score to a complete 10 right away.'

for its efficiency and sufficiently large hopper. 'We have used all kinds of collecting brooms, and every machine manufacturer has one, but I must say that the collecting broom of the Avant is one of the best we have used', Liespalo says.

### **The learning curve has been smooth**

When the drivers heard of the decision to acquire Avants, some of them were not immediately convinced. The change meant moving to machines of a smaller size class. After the introduction of the

There is none of this with the Avant. One significant advantage is that the hoses are always the right way up, it is not possible to connect them wrongly. We have found this to be a great development that saves a lot of time', Liespalo praises. Palmia also acknowledges the Avant for its work-friendliness and ergonomic design.

Liespalo looks forward to seeing good offers from Konetalo Vainikka over the coming year and sends his wishes to the factory: 'You are going in the right direction, just keep up with the product development!'

# Avant now provides a **2-year warranty!**

Starting from the beginning of 2015, Avant now offers an extended warranty program for two years. Similarly, the number of operating hours the warranty covers are extended depending on the models as follows:

- 2 years/500 operating hours for the Avant 200 series
- 2 years/750 operating hours for the Avant 300 and 400 series
- 2 years/1,000 operating hours for the Avant 500, 600, 700 and R series

We have invested heavily in the durability and reliability of our loaders, and the 20 years of development work is now seen in the extension of the product's life cycle. Avant loaders are not cheap, disposable machines, and we want our warranty periods to reflect this fact. The warranty's coverage remains at the same level as before: the longer warranty period does not signify a reduced service level.

An article appeared in this magazine about the previous update to the 500 series, and the hydraulics components of Avant's larger 600 and 700 series machines have also been updated to better endure the requirements of hard contracting work.

The longer warranty does not as such extend the life of the loader, but it is a proof of the manufacturer's belief in its products.

## Service interval extended **to 400 hrs/year**

Along with the extension of the warranty period, we have also introduced the extended service interval on several models. The run in or first service for all loaders remains 50 operating hours/one year, and it is the most important part of running in of the loader. After this, the loader's service interval has been set in hours or a one-year period. The service intervals for loaders made after 1 January 2015 are defined as follows:

- 200 hours/year: Avant 200, 300 and 400 series.
- 400 hours/year: Avant R, 500, 600 and 700 series.

The extension of the service interval is due the same reason as the extension of the warranty period. The high-quality components and long-term improvement of the reliability of the loaders also enable longer service intervals in several Avant models.







# Avant Tecno is expanding its manufacturing premises in Finland

**A**vant Tecno Oy has purchased the former industrial premises of Pilkington NSG, a 44,000 square-metre property located on the neighbouring plot. The property sale is significant in scale for Avant, and even for the entire region. Avant's factory hall space will more than double after the transaction.

“We were in a situation where we would have had to expand our premises in any case. For some of our operations, the facilities were just becoming too small. The property sale enables us to move our operations into new facilities quickly, providing us with much-needed space for our production”, says *Jani Käkälä*, Sales Director for Avant.

Avant will not take the entire property into use immediately, but a part of the production and shipping operations will

be transferred there quickly. The glass manufacturer Pilkington NSG will remain a tenant in the property, and will clearly be the largest individual tenant. For Avant Tecno Oy and its subsidiary Leguan Lifts Oy, which manufactures access platforms, the property sale enables the expansion of production in Ylöjärvi for a long time to come.

“With such a large facility, we now have too much space for our own operations, so at first we will be leasing a large part of the property out to external operators. However, the property sale will ensure our growth potential for the foreseeable future”, *Käkälä* says.

## **Avant Tecno is seeking growth in the United States – wide markets stabilise Avant's operations**

Avant's sales have grown continuously

in recent years despite the extremely challenging economic situation in Europe and Russia. Turnover for the financial period that ended in September 2014 amounted to a total of 82 million euros, which is the largest turnover in the company's history. At group level, turnover exceeded the level of 100 million euros for the first time. At the moment, Avant loaders are sold in more than 50 countries around the world. One of the reasons behind the success is the extent and versatile nature of the marketing area.

“We believe in a minimum annual growth of five per cent. The goal is to maintain our growth at approximately the same level in Europe. We will seek growth in the United States, where we established Avant Tecno USA approximately two and a half years ago”, *Käkälä* comments.







Have a great summer  
with Avant!

